



PLYWOOD | NAILED WOOD | PLASTIC  
HYBRID | WOOD/METAL | HARDBOARD | STAMPED METAL



**CARRISREELS**  
*employee-owned • customer-driven*

[WWW.CARRIS.COM](http://WWW.CARRIS.COM)

<b>Vermont</b>	Rutland, VT	(802)-773-9111 Tel	(802)-770-3551 Fax
<b>Connecticut</b>	Enfield, CT	(860)-749-8308 Tel	(860)-749-8558 Fax
<b>California</b>	Madera, CA	(559)-674-0804 Tel	(559)-674-0804 Fax
<b>Indiana</b>	New Carlisle, IN	(574)-654-8596 Tel	(574)-654-3149 Fax
<b>North Carolina</b>	Statesville, NC	(704)-872-0981 Tel	(704)-873-0654 Fax
<b>Virginia</b>	Fincastle, VA	(540)-473-2210 Tel	(540)-473-2878 Fax
<b>Texas</b>	McKinney, TX	(972)-542-3221 Tel	(972)-548-7335 Fax
	Bonham, TX	(903)-640-1503 Tel	(903)-640-1509 Fax
<b>Mexico</b>	Monterrey, MEX	+52(818)-316-7393 Tel	+52(818)-316-7395 Fax
<b>Canada</b>	St. Jerome, QC	(450)-431-3221 Tel	(450)-431-2433 Fax
	Bowmanville, ON	(905)-623-4455 Tel	(905)-623-9795 Fax

## SPECIFICATION AND QUOTATION SHEET

For a prompt quotation, please photocopy this form, complete it and fax to the Carris location nearest you: Carris California 559-674-0804  
Carris North Carolina 704-873-0654  
Carris Vermont at 802-770-3551



Company Name _____	Your Name _____	
Address _____	Position _____	
City _____	Phone _____	Fax _____

Type and size of material to be placed on reel: \_\_\_\_\_  
\_\_\_\_\_

Maximum weight of material to be placed on reel: \_\_\_\_\_

Quantities normally ordered: \_\_\_\_\_

A. Flange diameter: \_\_\_\_\_

B. Traverse length: \_\_\_\_\_

C. Barrel diameter: \_\_\_\_\_

D. Finish hole diameter: \_\_\_\_\_

E. Start hole diameter \_\_\_\_\_

F. Arbor hole diameter: \_\_\_\_\_

G. Distance center-to-center: \_\_\_\_\_

H. Lug hole diameter: \_\_\_\_\_

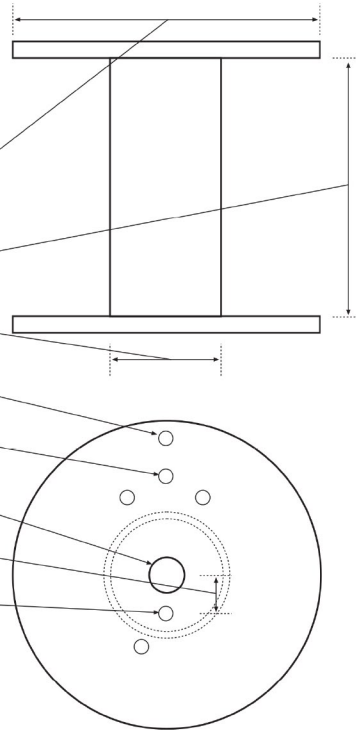

## HARDBOARD

Hardboard reels are suitable for a variety of applications, such as welding wire, ground wire, terminal contact strips, lightweight wire and cordage, fine drawn wires, twine, ribbon, jewelry chain, fiber optics and many others. The special feature of a hardboard reel is the strong, dense, smooth flange surfaces. Special flange machining can produce custom borings, such as sight holes or slots. The flanges can be custom printed with your logo or product information. Our standard method of shipping these reels to you on pallets and shrink-wrapped ensures that they are clean and undamaged when they arrive to your plant.

### FLANGE MATERIALS

#### High-Density Materials

- THICKNESS  $\frac{1}{8}$ " ,  $\frac{1}{4}$ " ,  $\frac{5}{16}$ "

#### Medium-Density Materials

- THICKNESS  $\frac{3}{8}$ " AND  $\frac{1}{2}$ " (OTHERS AS REQUESTED)

### BARREL MATERIALS

#### Paper Tubes

- SPIRAL WOUND FROM HIGH-GRADE PAPER AND GLUES
- INTENDED FOR USE WHERE MOISTURE IS NOT A CONCERN
- BEST BUY FOR THIS TYPE OF REEL

### FASTENERS

#### Rivets

- AVAILABLE IN  $\frac{3}{8}$ " AND  $\frac{1}{2}$ " DIAMETER TUBULAR STEEL
- IDEAL FOR LIGHTWEIGHT APPLICATIONS

#### Screws

- AVAILABLE IN  $\frac{1}{4}$ " IN BOTH FLAT HEAD AND ROUND HEAD LENGTHS UP TO 3" FOR "PANCAKE"-TYPE REELS.

#### Hex-head Bolts

- FOR LONGER TRAVERSE LENGTHS,  $\frac{1}{4}$ " BOLTS ARE USED

### STANDARD WELDING WIRE SIZES

8 x  $1\frac{3}{4}$  x  $3\frac{3}{8}$  WEIGHT CAPACITY OF 10 LBS

$11\frac{13}{16}$  x  $3\frac{3}{8}$  x  $8\frac{1}{4}$  WEIGHT CAPACITY OF 25 LBS

$11\frac{13}{16}$  x  $3\frac{3}{8}$  x  $6\frac{3}{8}$  WEIGHT CAPACITY OF 44 LBS

14 x  $3\frac{3}{8}$  x  $8\frac{1}{4}$  WEIGHT CAPACITY OF 44 LBS

Fastening options for Carris hardboard reels include rivets, screws, or hex-head bolts.

